

ชิ้นส่วนแม่พิมพ์ พลาสติก Injection Mould Parts



แคตตาล็อกนี้ยังอยู่ระหว่างการจัดทำ หากท่านต้องการให้เราส่งแคตตาล็อกเมื่อมีการเปลี่ยนแปลงให้ โปรดส่ง Email มาที่ info@sunrise.gr.com พร้อมระบุชื่อแคตตาล็อก ชื่อบริษัท ประเภทงานของบริษัทของท่าน
This Catalog is still in production. If you wish for update of this catalog, please send this catalog name , company name , type of business of the company to Email : info@sunrise.gr.com

Contents :

- Mould Insert
- Mould Coupler
- Mould Cooling
- Mould Shot Counter



Future Contents :

- Accessories
- Mould Locking
- Slide Core Unit
- Sliding Parts



หมวด : โมลด์อินเสิร์ท

Category : Mould Insert



Name	Date Marking Pin	Recycle Marking Pin	Gas Vent	Air Valve
Code	21 GDA	21 RMA , RMB	21 GAS1 , GAS2	21 GVJ
Page	3	4	5	6



Name	Air Poppet Valve	Air Jet Valve
Code	21 TVA	21 TVB
Page	6	6



Mould Shot Counter

โมลด์ช็อตเคาน์เตอร์ เครื่องนับจำนวนการใช้งานของแม่พิมพ์ฉีดพลาสติก สำหรับ ควบคุมอายุการใช้งานของแม่พิมพ์อย่างแม่นยำ ตัวเครื่องเป็นระบบ mechanic ไม่ใช้ไฟฟ้า ไม่สามารถเปลี่ยนแปลงตัวเลขได้
For tracking the number of use for each mould. The Mould Shot Counter is not resettable to give the most accurate counting of the pressing times of each mould, ensuring the limit number of each mould is not overuse.

- ! - 7 digits display
- 2 millions times guarantee
- No reset
- Max Temperature 120°C
- Water Resistance

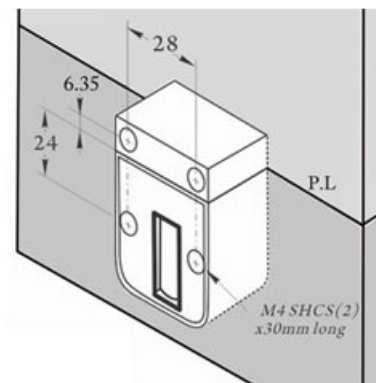
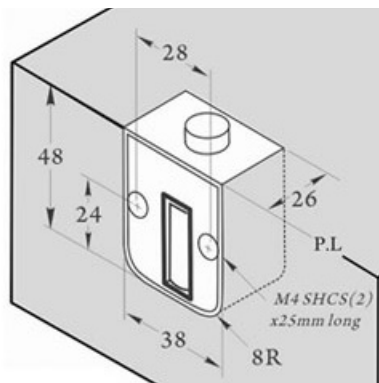

Qty Discount : 1-9pc 10-49pc 50-99pc 100-149pc 150pc +

Order Code	Application	Dimension (WxLxH)	Hex Socket Screw (M4x25)
21 MRSP	Internal Mount	26x38x48	2 pcs
21 MRSE	External Mount	26x38x48	4 pcs



Date Marking Pin

ตัวอักษรแสดง วัน-เดือน-ปี รุ่นมาตรฐาน
Standard type date marking pin.

M Stainless Steel
Hardness 46-58HRC

! Max Temperature 150°C

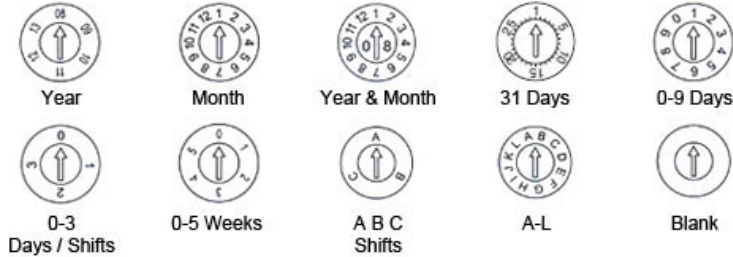
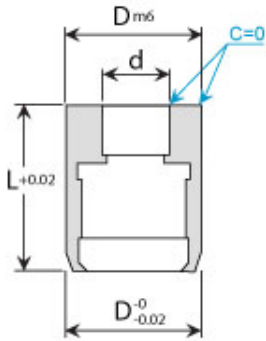

! - สามารถทำรูปแบบอื่นๆได้ โปรดส่งรูปภาพมาให้เรา
- Other design can be done, please send us your drawing.

Qty Discount : 1-9pc 10-49pc 50-99pc 100-149pc 150pc +

Code	D	L	d	Type	Type Code
21 GDA	03	08	1.5	Year	6Y
	04	08	2.0	Month	12M
	05	08	2.5	Year & Month	Y12M
	06	08	2.9	31 Days	31D
	08	10	3.9	0-9 Days	9D
	10	10	4.9	0-3 Days	3D
	10	12	4.9	0-5 Weeks	5W
	12	12	5.5	A B C Shifts	ABC
	12	12	5.5	A-L	AL
	16	14	7.4	Blank	AB
	20	14	8.7		

! Year Type

Order Code - D - L - 6Y - Starting Year last 2 digits
Example 21 GDA-10-12-6Y-12

! Year & Month Type

Order Code - D - L - Y12M - (Year last 2 digits - Y)
Example 21 GDA-10-12-Y12M-12Y

! Other Types

Order Code - D - L - Type Code
Example 21 GDA-10-12-12M

! - รูปแบบ 31Days ไม่สามารถผลิตได้สำหรับขนาด D 6mm. หรือเล็กกว่า
- '31 Days' type can not be produce if the D is 6mm or smaller.

Tips

- การหมุนตัวลูกศร ทำได้โดยการใช้ไขควงปลายแบนขนาดเล็กลงที่ลูกศร
- การติดตั้งควรเจาะรูทะลุขนาดเล็กลงกว่าตัว Date Marking Pin เพื่อใช้ในการปลดเมื่อจำเป็นจะต้องเปลี่ยนโดยใช้แท่งโลหะกระทุ้งจากด้านล่าง
- การติดตั้งเป็นแบบ Press-Fit, แต่ถ้าหากขนาดรูเล็กจนเกินไป อาจจะทำให้ไปบีบ Date Marking Pin มากจนไม่สามารถหมุนลูกศรได้
- ใช้ค้อนยาง หรือ ค้อนไม้ในการติดตั้งเพื่อรักษาผิวหน้าของ Date Marking Pin ไม่ให้เกิดรอยขีดข่วน

- To move the arrow, use flat screwdriver to turn the arrow.
- Always make a through drill hole smaller than the Date Marking Pin itself for removing.
- If the Press-Fit hole is too small, it might tighten the pin too hard the arrow can not rotate.
- Use soft face urethane or wood hammer during installation to save the surface of the pin.

1.

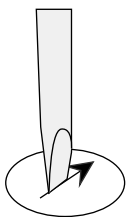

2.

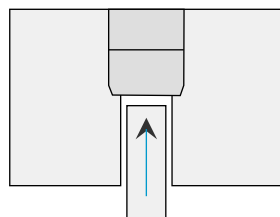

4.



M Urethane

ชั้นอย่างลดแรงกระแทก
Shock absorbant hammer.

Order Code	Hammer Face	Weight
09 E-035	35mm.	410g
09 E-050	50mm.	810g



Recycle Marking Pin

ตัวอักษรแสดง สัญลักษณ์รีไซเคิล มาตรฐาน USSPI และ German / French
USSPI and German / French recycle standard marking.

Stainless Steel
Hardness 46-58HRC

Max Temperature 150°C

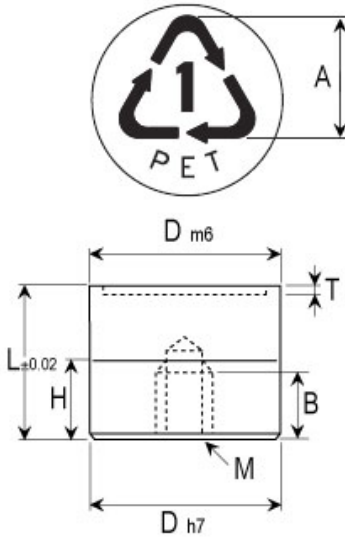

US SPI Standard (The Society of the Plastics Industry, Inc.)



German & French Standards (Comparable to US SPI)



Qty Discount : 1-9pc 10-49pc 50-99pc 100-149pc 150pc +

Order Code	D	L	M	A	T	B
21 RMA1, 21 RMA2, 21 RMA3, 21 RMA4, 21 RMA5 21 RMA6, 21 RMA7, 21 RMB1, 21 RMB2, 21 RMB3 21 RMB4G, 21 RMB4F, 21 RMB7	8	10	M4	5	0.2	5
	10	12	M5	6	0.3	7
	12	14	M5	7	0.3	7
	16	14	M6	10	0.3	7
	20	16	M6	12	0.3	8

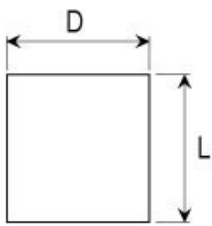

Sintered
Stainless Steel



21 GAS1

Sintered
Bronze



21 GAS2

Gas Vent

แห่งระบายอากาศ ด้วยรูระบายอากาศที่เล็กพิเศษ ช่วยให้การฉีด
พลาสติกออกมาสมบูรณ์แบบ ไม่มีร่องอากาศในเนื้อพลาสติก

Gas Vent help release the air and gas build up which
result in better product quality.

Qty Discount : 1-9pc 10-49pc 50-99pc 100-149pc 150pc +

Order Code	D	L
21 GAS1	05	10
21 GAS2	06	10
	08	10
	10	10
	12	12

Order Code - D - L
Example 21 GAS1 06-10

Stainless Steel
Bronze

Pore sizes : 0.035 - 0.050 mm.

1. สามารถขัดผิวแห่งระบายอากาศไปพร้อมกับผิวแม่พิมพ์ได้
เมื่อขัดขึ้นรูปเสร็จควรใช้ลมเป่าเพื่อไล่เศษผงออกให้หมด

2. ข้อเสนอแนะการเลือกใช้ :

Stainless Steel : แม่พิมพ์ฉีดพลาสติก (Injection)

Bronze : แม่พิมพ์แวคคัม (Vacuum)

1. The Gas Vent surface can be work on with
polishing tools along with the mould. Then
use air to blow the powder out of the vent.

2. Usage recommendation :

Stainless Steel : Injection Mould

Bronze : Vacuum Mould

Air Valve / Air Jet Valve / Air Poppet Valve

ใช้สำหรับแม่พิมพ์ที่เกิดปัญหาชิ้นงานติดกับแม่พิมพ์เนื่องจากลักษณะของชิ้นงานทำให้เกิดสุญญากาศ (เช่น แก้วน้ำ) ทำงานด้วยแรงลม ด้วยการผลักชิ้นงานจากด้านที่ติดแล้วจึงสามารถทำการปลดชิ้นงานด้วยวิธีปกติ

The valves are use to help releasing deep-draw or thin wall products (i.e. cups) which create vacuum and usually are stuck on the mould. By using the valve to push from inside the final product using air, they can be easily eject by normal methods.



Air Valve

แอร์วาล์ว รูปแบบที่ได้รับความนิยมในยุโรป และ เอเชีย
Air Valve, European type.

Stainless Steel
Hardness 50-54HRC

Min Working Pressure 3 Bar
Max Temperature 150°C

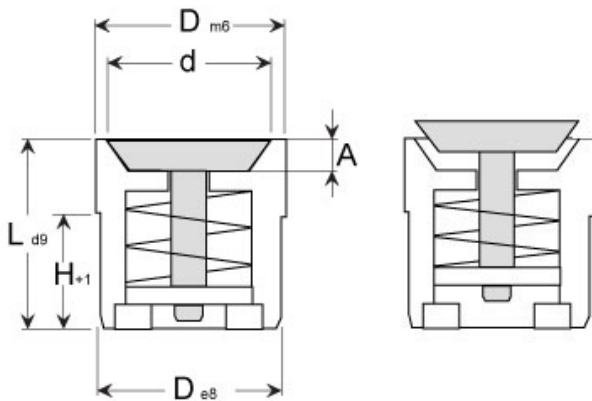

Qty Discount : 1-9pc 10-49pc 50-99pc 100-149pc 150pc +

Order Code	D	d	L	A	H
21 GVJ-06	06	5.2	12	1.5	7
21 GVJ-08	08	6.5	12	1.5	7
21 GVJ-10	10	8	12	2	7
21 GVJ-12	12	10	12	2.5	7
21 GVJ-16	16	13	20	3	12
21 GVJ-20	20	17	20	3.5	12

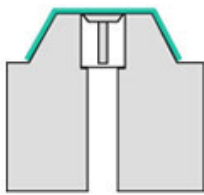

1. ชิ้นงานที่ฉีดเสร็จแล้วติดกับแม่พิมพ์ ทำให้ไม่สามารถปลดออกได้โดยไม่เกิดความเสียหาย

The final product get stuck with the mould because of the vacuum effect. It is not possible to eject the part without risk of damaging it.

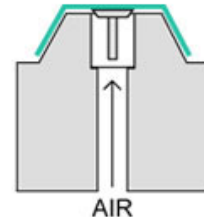

2. เมื่อเป่าลมเข้าไปจากทางด้านล่างของแอร์วาล์ว แรงลมจะไปดันให้ตัววาล์วเปิดออกและทำให้ความเป็นสุญญากาศหายไป และยกชิ้นงานลอยขึ้นเพื่อทำการปลดชิ้นงานต่อไป (ความแรงของลมขั้นต่ำที่ใช้ได้จาก Min Working Pressure)

When the air is blow through the bottom of Air Valve, it will push the valve up and relief the vacuum effect on the final product. During the period the valve lifting up the product, ejecting it can be easily done.



Air Poppet Valve

แอร์ป๊อปเป็ทวาวล์ รูปแบบที่ได้รับความนิยมในอเมริกา
Air Poppet Valve, American type.

Stainless Steel
Hardness 50-54HRC

Min Working Pressure 4 Bar
Max Temperature 120°C

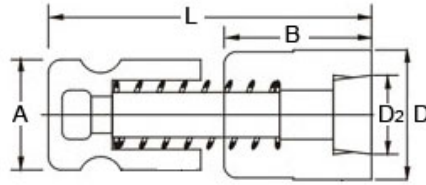

Qty Discount : 1-9pc 10-49pc 50-99pc 100-149pc 150pc +

Order Code	D	D2	B	L	A
21 TVA-08	8	6.6	11	24	6
21 TVA-10	10	8.0	11	24	6
21 TVA-12	12	9.7	18	34	8
21 TVA-16	16	13.0	20	38	8
21 TVA-18	18	14.8	22	46	12
21 TVA-20	20	16.0	26	50	12
21 TVA-25	25	20.0	26	50	12



Air Jet Valve

แอร์เจ็ทวาวล์ รูปแบบที่ได้รับความนิยมในญี่ปุ่น
Air Jet Valve, Japanese type.

Stainless Steel
Hardness 50-54HRC

Min Working Pressure 4 Bar
Max Temperature 120°C

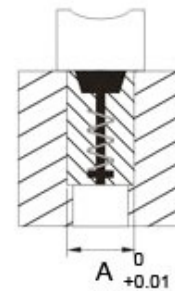

Qty Discount : 1-9pc 10-49pc 50-99pc 100-149pc 150pc +

Order Code	D	L	A	C
21 TVB-08	8	15	8	4.5
21 TVB-10	10	20	10	7
21 TVB-12	12	25	12	7.7
21 TVB-16	16	30	16	10.3
21 TVB-20	20	35	20	12.9
21 TVB-25	25	45	25	14.9
21 TVB-30	30	45	30	18

หมวด : คัปปลิ่งแม่พิมพ์

Category : Mould Coupler



Name	A Type	Hose Socket	L Hose Socket	Hose 45 Socket	Male Socket
Code	21 301 , 401				
Page	8-10	8	8	8	8



Name	Female Socket	Coupler Plug	L Coupler Plug	Hose Coupler Plug	Long Coupler Plug
Code					
Page	9	9	9	9	10

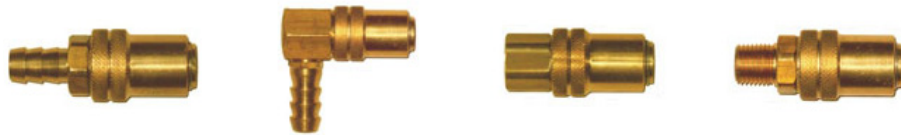

Name	J Type	Hose Socket	L Hose Socket	Female Socket	Male Socket
Code	21 601 , 701				
Page	10-11	10	10	10	11



Name	Coupler Plug	L Coupler Plug	Long Coupler Plug	Quick Fitting Joints	
Code				21 SPC	21 SPCF
Page	11	11	11	12	12



Name	Quick Fitting Joints					
Code	21 SPH	21 SPLFL	21 SPLL	21 SPLEL	21 SLL	21 SPXY
Page	12	12	13	13	13	13



Name	Quick Fitting Joints	
Code	21 SPLBT	21 SPLDT
Page	14	14

Mould Coupler

ข้อต่อคัปปลิ่ง A-Type
A-Type Couplers

ข้อต่อคัปปลิ่ง A-Type รุ่น 301 และ 401 สำหรับระบบน้ำหล่อเย็นแม่พิมพ์
สำหรับตัวข้อต่อซ็อกเก็ตสามารถเลือกแบบมีวาล์ว และ ไม่มีวาล์วได้

A-Type Couplers series 301 and 401 for mould cooling system.
The sockets can be choose between with or without valve.

A-Type



Qty Discount : 1-9pc 10-49pc 50-99pc 100-149pc 150pc +

Hose Socket

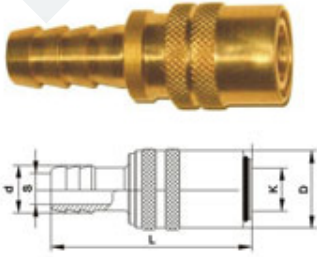

Code		Series	D	L	d	K	S
Valve	No Valve						
21 301-2	21 301-2-0	A Type 301	17	52	7.3	9.7	5
21 301-3	21 301-3-0				10.5		6
21 301-4	21 301-4-0				14		9
21 401-3	21 401-3-0	A Type 401	22	63	10.5	13.5	6
21 401-4	21 401-4-0				14		9

L Hose Socket

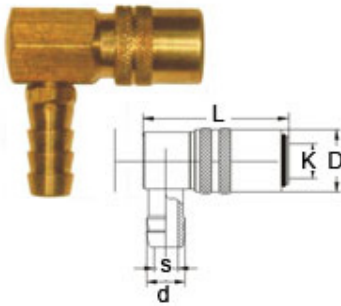

Code		Series	D	L	d	K	S
Valve	No Valve						
21 301-L2	21 301-L2-0	A Type 301	17	46.5	7.3	9.7	6
21 301-L3	21 301-L3-0				10.5		6
21 301-L4	21 301-L4-0				14		9
21 401-L3	21 401-L3-0	A Type 401	22	62	10.5	13.5	6
21 401-L4	21 401-L4-0				14		9

Hose 45 Socket

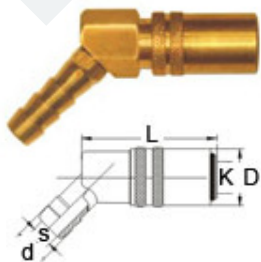

Code		Series	D	L	d	K	S
Valve	No Valve						
21 301-Y2	21 301-Y2-0	A Type 301	17	46.5	7.3	9.7	6
21 301-Y3	21 301-Y3-0				10.5		6
21 301-Y4	21 301-Y4-0				14		9
21 401-Y3	21 401-Y3-0	A Type 401	22	62	10.5	13.5	6
21 401-Y4	21 401-Y4-0				14		9

Male Socket

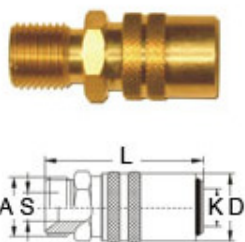

Code		Series	D	L	A	K	S
Valve	No Valve						
21 301-1/8	21 301-1/8-0	A Type 301	17	46	1/8PT	9.7	6
21 301-1/4	21 301-1/4-0				1/4PT		9
21 401-1/4	21 401-1/4-0	A Type 401	22	57.5	1/4PT	13.5	9
21 401-3/8	21 401-3/8-0				3/8PT		12
21 401-1/2	21 401-1/2-0				1/2PT		14

Female Socket

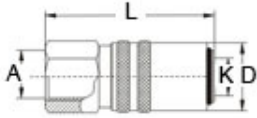

Code		Series	D	L	A	K
Valve	No Valve					
21 301-A1/8	21 301-A1/8-0	A Type 301	17	46	1/8PT	9.7
21 301-A1/4	21 301-A1/4-0				1/4PT	
21 401-A1/4	21 401-A1/4-0	A Type 401	22	57.5	1/4PT	13.5
21 401-A3/8	21 401-A3/8-0				3/8PT	
21 401-A1/2	21 401-A1/2-0				1/2PT	

Coupler Plug

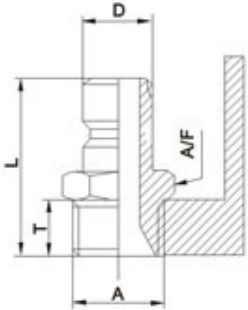

Code	Series	D	L	A	T	A/F
21 301-01PT-M	A Type 301	9.5	29	1/8PT	12	11
21 301-02PT-M				1/4PT		14
21 301-03PT-M			3/8PT	17		
21 301-04PT-M			1/2PT	21		
21 401-01PT-M	A Type 401	13.5	34	1/8PT	12	11
21 401-02PT-M				1/4PT		14
21 401-03PT-M			3/8PT	17		
21 401-04PT-M			1/2PT	21		

L Coupler Plug

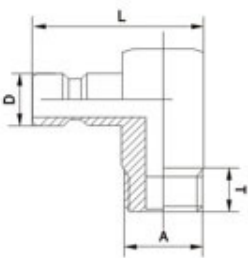

Code	Series	D	L	A	T	H
21 301-01PT-L	A Type 301	9.5	29.5	1/8PT	12	15
21 301-02PT-L				1/4PT		
21 301-03PT-L			3/8PT	14	20	
21 401-01PT-L	A Type 401	13.5	34.5	1/8PT	12	15
21 401-02PT-L				1/4PT		
21 401-03PT-L			3/8PT	14	20	

Hose Coupler Plug

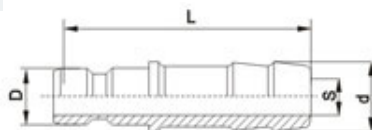

Code	Series	D	L	d
21 301-10-M	A Type 301	9.5	34	10
21 401-13-M	A Type 401	13.5	35	13

Mould Coupler

ข้อต่อคัปปลิ่ง A-Type / J-Type
A-Type / J-Type Couplers

Long Coupler Plug

คัปปลิ่งปลั๊กตัวยาว สามารถเลือกความยาวได้
The length of this type can be chosen.

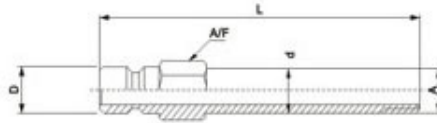

Order Code - L
Example 21 301-01PT-50

Code	L	Series	D	A	d	A/F
21 301-01PT	50 , 75 , 100 , 125 , 150 , 200 , 250	A Type 301	9.5	1/8PT	10	11
21 301-02PT				1/4PT	13	14
21 301-03PT				3/8PT	16.5	17
21 401-01PT	50 , 75 , 100 , 125 , 150 , 200 , 250	A Type 401	13.5	1/8PT	10	14
21 401-02PT				1/4PT	13	14
21 401-03PT				3/8PT	16.5	17

ข้อต่อคัปปลิ่ง J-Type รุ่น 601 และ 701 สำหรับระบบน้ำหล่อเย็นแม่พิมพ์
สำหรับตัวข้อต่อซ็อกเก็ตสามารถเลือกแบบมีวาล์ว และ ไม่มีวาล์วได้

J-Type Couplers series 601 and 701 for mould cooling system.
The sockets can be choose between with or without valve.

J-Type



Qty Discount : 1-9pc 10-49pc 50-99pc 100-149pc 150pc +

Hose Socket

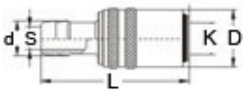

Code		Series	D	L	d	K	S
Valve	No Valve						
21 601-2	21 601-2-0	J Type 601	18.5	61.5	8.5	10.0	4.5
21 601-3	21 601-3-0				11.0		6.0
21 601-4	21 601-4-0				14.0		9.0
21 701-3	21 701-3-0	J Type 701	22.0	67.0	11.0	13.0	6.0
21 701-4	21 701-4-0				14.0		9.0

L Hose Socket

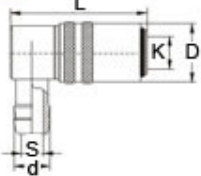
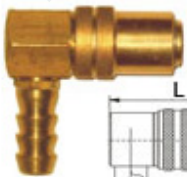

Code		Series	D	L	d	K	S
Valve	No Valve						
21 601-L2	21 601-L2-0	J Type 601	18.5	48.0	8.5	10.0	4.5
21 601-L3	21 601-L3-0				11.0		6.0
21 601-L4	21 601-L4-0				14.0		6.0
21 701-L3	21 701-L3-0	J Type 701	22.0	60.0	11.0	13.0	7.0
21 701-L4	21 701-L4-0				14.0		7.0

Female Socket

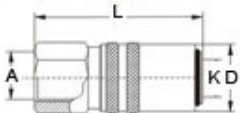

Code		Series	D	L	A	K
Valve	No Valve					
21 601-A1/4	21 601-A1/4-0	J Type 601	18.5	48.0	1/4PT	10.0
21 601-A3/8	21 601-A3/8-0				3/8PT	
21 701-A1/4	21 701-A1/4-0	J Type 701	22.0	61.0	1/4PT	13.0
21 701-A3/8	21 701-A3/8-0				3/8PT	

Male Socket

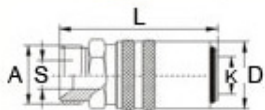

Code		Series	D	L	A	K	S
Valve	No Valve						
21 601-1/4	21 601-1/4-0	J Type 601	18.5	51.0	1/4PT	10.0	6.0
21 601-3/8	21 601-3/8-0				3/8PT		
21 701-1/4	21 701-1/4-0	J Type 701	22.0	58.0	1/4PT	13.0	9.0
21 701-3/8	21 701-3/8-0				3/8PT		

Coupler Plug

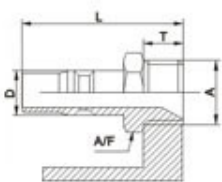

Code	Series	D	L	A	T	A/F
21 601-01PT-M	J Type 601	10.0	33.0	1/8PT	12.0	11.0
21 601-02PT-M				1/4PT		14.0
21 601-03PT-M				3/8PT		17.0
21 701-01PT-M	J Type 701	13.0	38.0	1/8PT	12.0	14.0
21 701-02PT-M				1/4PT		14.0
21 701-03PT-M				3/8PT		17.0

L Coupler Plug

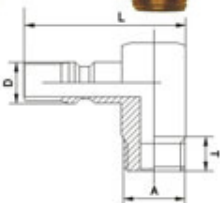

Code	Series	D	L	A	T	H
21 601-01PT-L	J Type 601	10.0	34.0	1/8PT	12.0	15.0
21 601-02PT-L				1/4PT		20.0
21 601-03PT-L				3/8PT		20.0
21 701-01PT-L	J Type 701	13.0	39.0	1/8PT	12.0	15.0
21 701-02PT-L				1/4PT		15.0
21 701-03PT-L				3/8PT		20.0

Long Coupler Plug

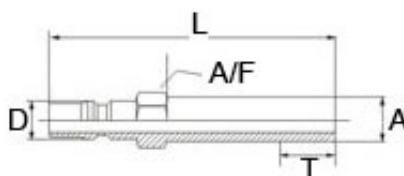

คัปปลิ่งปลั๊กตัวยาว สามารถเลือกความยาวได้ตามต้องการ
The length of this type can be chosen.

Order Code - L
Example 21 601-02PT-75

Code	L	D	Series	A	T	A/F
21 601-01PT	75 , 100 , 125 , 150 , 200 , 250	10.0	J Type 601	1/8PT	12.0	11.0
21 601-02PT				1/4PT		14.0
21 701-01PT	75 , 100 , 125 , 150 , 200 , 250	13.0	J Type 701	1/8PT	12.0	14.0
21 701-02PT				1/4PT		14.0

ข้อต่อสวมเร็ว สำหรับสวมสายยางท่อลมและน้ำได้อย่างรวดเร็ว เลือกใช้ตามขนาดสายยางที่ใช้งาน (D)

Quick Fitting Joints for fast air and water hose fitting. Choosing the right size from the diameter of hose (D) to be use with.

Quick Fitting Joints

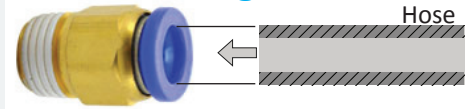

Qty Discount : 1-9pc 10-49pc 50-99pc 100-149pc 150pc +

Quick Fitting Joint 21 SPC



Code	Matching Tube O.D.	Thread Size	
		D	Nominal R(PT)
21 SPC	4	01PT	1/8 PT
		02PT	1/4 PT
		03PT	3/8 PT
	6	01PT	1/8 PT
		02PT	1/4 PT
		03PT	3/8 PT
		04PT	1/2 PT
	8	01PT	1/8 PT
		02PT	1/4 PT
		03PT	3/8 PT
		04PT	1/2 PT
	10	01PT	1/8 PT
02PT		1/4 PT	
03PT		3/8 PT	
04PT		1/2 PT	
12	02PT	1/4 PT	
	03PT	3/8 PT	
	04PT	1/2 PT	
16	03PT	3/8 PT	
	04PT	1/2 PT	
	06PT	3/4 PT	

Female Quick Fitting Joint 21 SPCF



Code	Matching Tube O.D.	Thread Size	
		D	Nominal Rc(PT)
21 SPCF	4	01PT	1/8 PT
		02PT	1/4 PT
		03PT	3/8 PT
	6	01PT	1/8 PT
		02PT	1/4 PT
		03PT	3/8 PT
	8	01PT	1/8 PT
		02PT	1/4 PT
		03PT	3/8 PT
		04PT	1/2 PT
	10	01PT	1/8 PT
		02PT	1/4 PT
03PT		3/8 PT	
12	02PT	1/4 PT	
	03PT	3/8 PT	
	04PT	1/2 PT	

Brass Resin

Work Temperature : 0-60°C
Max Pressure : 150psi

Order Code - D - Nominal
Example 21 SPC8-02PT

Turn L Quick Fitting Joint 21 SPH

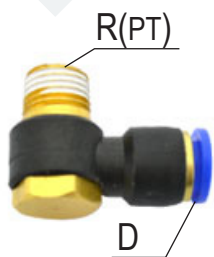

Code	Matching Tube O.D.	Thread Size	
		D	Nominal R(PT)
21 SPH	4	01PT	1/8 PT
		02PT	1/4 PT
		03PT	3/8 PT
	6	01PT	1/8 PT
		02PT	1/4 PT
		03PT	3/8 PT
		04PT	1/2 PT
	8	01PT	1/8 PT
		02PT	1/4 PT
		03PT	3/8 PT
		04PT	1/2 PT
	10	01PT	1/8 PT
02PT		1/4 PT	
03PT		3/8 PT	
04PT		1/2 PT	
12	02PT	1/4 PT	
	03PT	3/8 PT	
	04PT	1/2 PT	

Female L Quick Fitting Joint 21 SPLFL



Code	Matching Tube O.D.	Thread Size	
		D	Nominal Rc(PT)
21 SPLFL	4	01PT	1/8 PT
		02PT	1/4 PT
		03PT	3/8 PT
	6	01PT	1/8 PT
		02PT	1/4 PT
		03PT	3/8 PT
	8	01PT	1/8 PT
		02PT	1/4 PT
		03PT	3/8 PT
		04PT	1/2 PT
	10	01PT	1/8 PT
		02PT	1/4 PT
03PT		3/8 PT	
12	02PT	1/4 PT	
	03PT	3/8 PT	
	04PT	1/2 PT	

L Quick Fitting Joint
21 SPLL



Code	Matching Tube O.D. D	Thread Size	
		Nominal	R(PT)
21 SPLL	4	01PT	1/8 PT
		02PT	1/4 PT
		03PT	3/8 PT
	6	01PT	1/8 PT
		02PT	1/4 PT
		03PT	3/8 PT
	8	01PT	1/8 PT
		02PT	1/4 PT
		03PT	3/8 PT
		04PT	1/2 PT
	10	01PT	1/8 PT
		02PT	1/4 PT
03PT		3/8 PT	
12	02PT	1/4 PT	
	03PT	3/8 PT	
	04PT	1/2 PT	
16	03PT	3/8 PT	
	04PT	1/2 PT	
	06PT	3/4PT	

Long L
Quick Fitting Joint
21 SPLEL

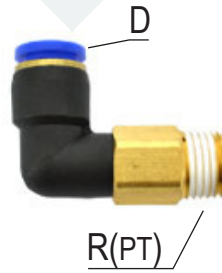

Code	Matching Tube O.D. D	Thread Size	
		Nominal	R(PT)
21 SPLEL	4	01PT	1/8 PT
		02PT	1/4 PT
		03PT	3/8 PT
	6	01PT	1/8 PT
		02PT	1/4 PT
		03PT	3/8 PT
	8	01PT	1/8 PT
		02PT	1/4 PT
		03PT	3/8 PT
		04PT	1/2 PT
	10	01PT	1/8 PT
		02PT	1/4 PT
03PT		3/8 PT	
12	02PT	1/4 PT	
	03PT	3/8 PT	
	04PT	1/2 PT	

Brass Resin

Work Temperature : 0-60°C
Max Pressure : 150psi

Order Code - D - Nominal
Example 21 SPLL8-02PT

Qty Discount : 1-9pc 10-49pc 50-99pc 100-149pc 150pc +

Flow Control
Quick Fitting Joint
21 SLL

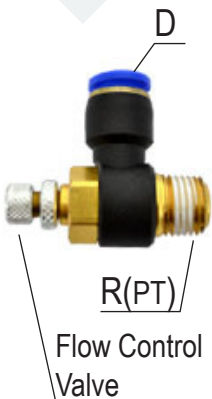

Code	Matching Tube O.D. D	Thread Size	
		Nominal	R(PT)
21 SLL	4	01PT	1/8 PT
		02PT	1/4 PT
	6	01PT	1/8 PT
		02PT	1/4 PT
	8	03PT	3/8 PT
		01PT	1/8 PT
		02PT	1/4 PT
	10	03PT	3/8 PT
		04PT	1/2 PT
		01PT	1/8 PT
	12	02PT	1/4 PT
		03PT	3/8 PT
04PT		1/2 PT	
116	04PT	1/2 PT	

Y Quick Fitting Joint
21 SPXY



Code	Matching Tube O.D. D	Thread Size	
		Nominal	R(PT)
21 SPXY	4	01PT	1/8 PT
		02PT	1/4 PT
		03PT	3/8 PT
	6	01PT	1/8 PT
		02PT	1/4 PT
		03PT	3/8 PT
	8	04PT	1/2 PT
		01PT	1/8 PT
		02PT	1/4 PT
	10	03PT	3/8 PT
		04PT	1/2 PT
		01PT	1/8 PT
12	02PT	1/4 PT	
	03PT	3/8 PT	
	04PT	1/2 PT	
16	02PT	1/4 PT	
	03PT	3/8 PT	
	04PT	1/2 PT	
	06PT	3/4 PT	

T Quick Fitting Joint
21 SPLBT

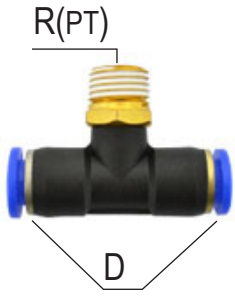

Code	Matching Tube O.D. D	Thread Size	
		Nominal	R(PT)
21 SPBT	4	01PT	1/8 PT
		02PT	1/4 PT
		03PT	3/8 PT
	6	01PT	1/8 PT
		02PT	1/4 PT
		03PT	3/8 PT
		04PT	1/2 PT
	8	01PT	1/8 PT
		02PT	1/4 PT
		03PT	3/8 PT
		04PT	1/2 PT
	10	01PT	1/8 PT
02PT		1/4 PT	
03PT		3/8 PT	
04PT		1/2 PT	
12	02PT	1/4 PT	
	03PT	3/8 PT	
	04PT	1/2 PT	
16	03PT	3/8 PT	
	04PT	1/2 PT	
	06PT	3/4 PT	

Side T
Quick Fitting Joint
21 SPLDT

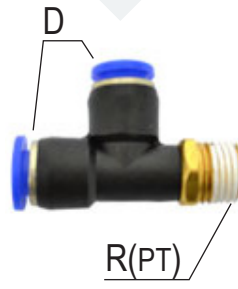

Code	Matching Tube O.D. D	Thread Size	
		Nominal	R(PT)
21 SPDT	4	01PT	1/8 PT
		02PT	1/4 PT
		03PT	3/8 PT
6	6	01PT	1/8 PT
		02PT	1/4 PT
		03PT	3/8 PT
		04PT	1/2 PT
8	8	01PT	1/8 PT
		02PT	1/4 PT
		03PT	3/8 PT
		04PT	1/2 PT
10	10	01PT	1/8 PT
		02PT	1/4 PT
		03PT	3/8 PT
		04PT	1/2 PT
12	12	02PT	1/4 PT
		03PT	3/8 PT
		04PT	1/2 PT
16	16	03PT	3/8 PT
		04PT	1/2 PT
		06PT	3/4 PT



Brass Resin



Work Temperature : 0-60°C
Max Pressure : 150psi

Order
Example

Code - D - Nominal
21 SPL8-02PT

Qty Discount : 1-9pc 10-49pc 50-99pc 100-149pc 150pc +

หมวด : โมลด์คูลลิ่ง

Category : Mould Cooling



Name	Hose Nipple	Long Hose Nipple	Ball Valve	L-Swivel Hose Nipple
Code	21 CT	21 CT - L	21 VC	21 C-LSN
Page	16	16	16	17



Name	Cooling Joint Plug	Water Flow Meter	Cooling Circuit Plug	Tapered Screw Plug
Code	21 JN	21 FM , FMV	21 GCCP	21 ES , AS
Page	17	17	18	18



Name	Uni-Joint Tube
Code	21 FC
Page	19

Hose Nipple

ข้อต่อทางปลาไหล ใช้สวมเข้ากับสายยาง
Hose Nipple for connecting to hose.

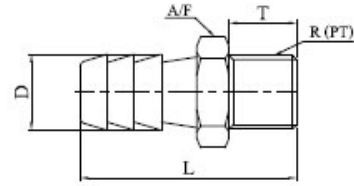

Qty Discount : 1-9pc 10-49pc 50-99pc 100-149pc 150pc +

⚠ Max pressure 9.8Bar

Ⓜ Brass

Order Code	D	A	T	A/F
21 CT-301PT-M	11.0	1/8PT	12.0	11.0
21 CT-302PT-M		1/4PT		14.0
21 CT-303PT-M		3/8PT		17.0
21 CT-401PT-M	14.0	1/8PT	12.0	11.0
21 CT-402PT-M		1/4PT		14.0
21 CT-403PT-M		3/8PT		17.0

Long Hose Nipple

ข้อต่อทางปลาไหล รุ่นเลือกความยาว
Hose Nipple with chooseable length.

⚠ Max pressure 9.8Bar

Ⓜ Brass

Order Code - L
Example 21 CT-302PT-100

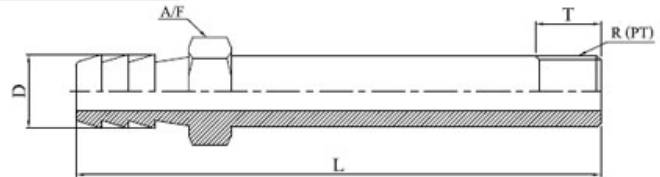

Qty Discount : 1-9pc 10-49pc 50-99pc 100-149pc 150pc +

Code	L	D	A	T	A/F
21 CT-301PT	75 , 100 , 125 , 150 , 200 , 250	11.0	1/8PT	12.0	11.0
21 CT-302PT			1/4PT		14.0
21 CT-303PT			3/8PT		17.0
21 CT-401PT	75 , 100 , 125 , 150 , 200 , 250	14.0	1/8PT	12.0	11.0
21 CT-402PT			1/4PT		14.0
21 CT-403PT			3/8PT		17.0

Ball Valve

บอลวาล์วทองเหลือง
Brass Ball Valve.

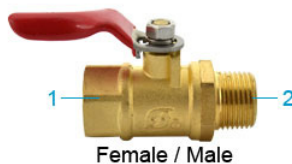
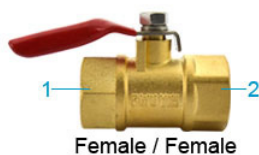

⚠ Max pressure 41.2Bar
For water / air / oil

Ⓜ Brass
Fluoro Resin

Qty Discount : 1-9pc 10-49pc 50-99pc 100-149pc 150pc +

Order Code	Type	1	2
21 VC-02PT	Female / Female	1/4PT	1/4PT
21 VC-03PT		3/8PT	3/8PT
21 VC-04PT		1/2PT	1/2PT
21 VC-02PT-2	Female / Male	1/4PT	1/4PT
21 VC-03PT-3		3/8PT	3/8PT
21 VC-04PT-4		1/2PT	1/2PT

Mould Cooling

ข้อต่อทางปลาไหลตัว L หัวหมุน 360 องศา. ท่อคูลิ่งจ๊อยท์ . โพลวมิเตอร์
L-Swivel Hose Nipple . Cooling Joint Plug . Water Flow Meter



L-Swivel Hose Nipple

ข้อต่อทางปลาไหลรูปตัว L หัวหมุนได้ 360 องศา สำหรับสวมสายยาง
The L-shape Hose Nipple head can rotate 360 degree.

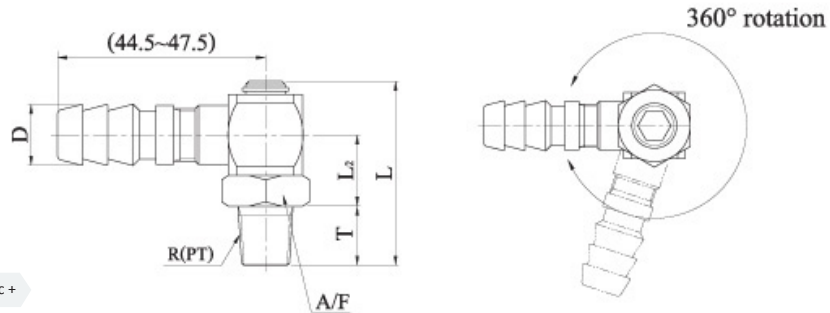

⚠ Max pressure 9.8Bar
Max Temperature 200°C

Ⓜ Brass
Synthetic Rubber

Qty Discount : 1-9pc 10-49pc 50-99pc 100-149pc 150pc +

Order Code	R	D	L	L2	A/F	T
21 C-LSN-1	1/8PT	11	36.5	15.75	19	9.5
21 C-LSN-2	1/4PT	11	39.5	15.75	19	12.5
21 C-LSN-3	3/8PT	11	42.5	17.75	19	13.5

Cooling Joint Plug

ท่อคูลิ่งจ๊อยท์ สำหรับระบบน้ำหล่อเย็นแม่พิมพ์
Cooling Joint for connecting cooling water into mould.

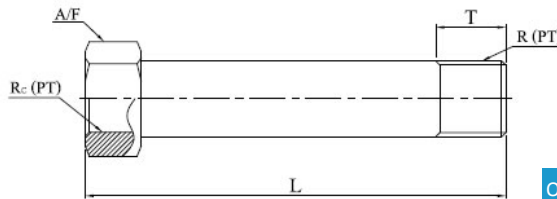

Qty Discount : 1-9pc 10-49pc 50-99pc 100-149pc 150pc +

⚠ Max pressure: 9.8Bar Ⓜ Brass

Order Code - L
Example 21 JN01-01PT-125

Code	L	T	Rc	R	A/F
21 JN01-01PT	50 , 75 , 100 , 125 , 200 , 250	12.0	1/8PT	1/8PT	14.0
21 JN02-02PT	50 , 75 , 100 , 125 , 200 , 250	12.0	1/4PT	1/4PT	17.0

Water Flow Meter

โพลวมิเตอร์ สำหรับตรวจการเดินของน้ำหล่อเย็นในแม่พิมพ์
Checking the flow of cooling water in Mould.



21 FM-03PT

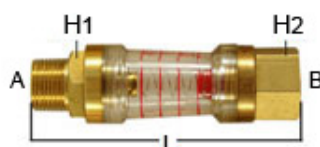

21 FM-03PT-3

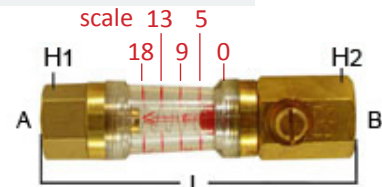

21 FMV-03PT

Qty Discount : 1-9pc 10-49pc 50-99pc 100-149pc 150pc +

⚠ Max Pressure: 8 Bar
Max Flow Rate: 18L/Min

⚠ Max Temperature: 60°C

Ⓜ Body : Brass
Scale : Plastic

Order Code	Type	H1 (Hexagon)	H2 (Hexagon)	A	B	L
21 FM-03PT	Double female thread	21	21	Female 3/8PT	Female 3/8PT	84
21 FM-03PT-3	Male + Female thread	21	21	Male 3/8PT	Female 3/8PT	81
21 FMV-03PT	Double female thread+valve	21	23	Female 3/8PT	Female 3/8PT	97.5

Cooling Circuit Plug

ปลั๊กอุดรูน้ำรุ่นสุดได้ทุกที่โดยไม่ต้องต๊าปเกลียวรู ทำให้การปรับทิศทางของน้ำหล่อเย็นเป็นไปได้ง่ายขึ้น

Threadless type sealing plug for cooling water hole, the plug can be place almost anywhere.

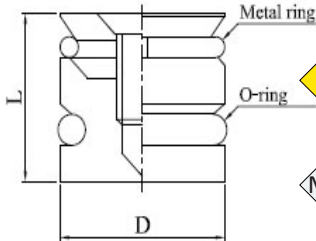

⚠ Max Pressure: 6 Bar
Max Temperature: 100°C
For water / oil

Ⓜ Body: Brass
O-Ring: Synthetic Rubber

⚠ ติดตั้งด้วยการใช้เพลยาวยันท้ายของปลั๊กอุดรูน้ำเอาไว้แล้วใช้ไขควงยาวขันตัวปลั๊ก จะทำให้ตัวปลั๊กขยายตัวออกมาเบียดเข้ากับรูน้ำ

Install by using long rod to hold the Cooling Circuit Plug in place, then fasten it with long screw driver.

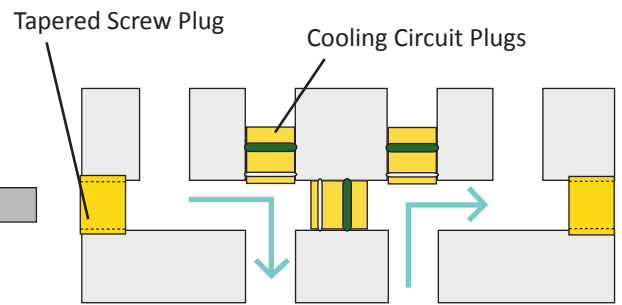
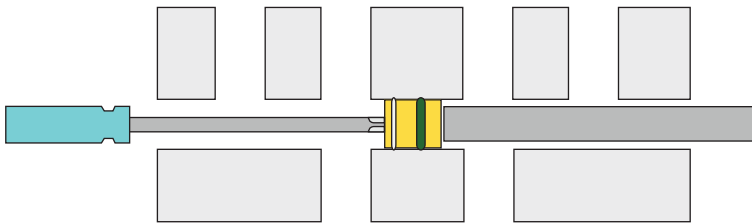

Order Code	D	L
21 GCCP06-10	6	10
21 GCCP08-10	8	10
21 GCCP10-11	10	11
21 GCCP12-12	12	12
21 GCCP14-13	14	13
21 GCCP16-14	16	14
21 GCCP18-16	18	16
21 GCCP20-19	20	19
21 GCCP25-19	25	19
21 GCCP30-19	30	19

Qty Discount : 1-9pc 10-49pc 50-99pc 100-149pc 150pc +

Tapered Screw Plug

สกรูเทเปอร์ปลั๊กทองเหลือง สำหรับอุดรูน้ำหล่อเย็นแม่พิมพ์ และของเหลวอื่นๆ ทนแรงดันได้สูง

For sealing cooling water holes in mould, or use for other liquid sealing. It can withstand high pressure.

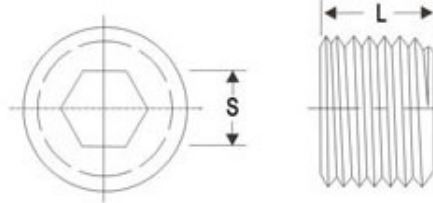

⚠ มีให้เลือกแบบเกลียว PT และ NPT
Available in PT and NPT type

⚠ Max pressure: 41.2Bar
For water / oil / steam

Ⓜ Brass

Qty Discount : 1-9pc 10-49pc 50-99pc 100-149pc 150pc +

Order Code	Thread	L (mm)	Hex S (mm)	Thread / 25.4mm.
21 ES-01PT	1/8 PT	7.0	5.0	28.0
21 ES-02PT	1/4 PT	8.9	6.0	19.0
21 ES-03PT	3/8 PT	10.0	8.0	19.0
21 ES-04PT	1/2 PT	12.0	10.0	14.0
21 ES-06PT	3/4 PT	14.0	14.0	14.0
21 ES-08PT	1 PT	16.5	17.0	11.0

Order Code	Thread	L (inch)	Hex S (inch)	Thread / inch
21 AS-01NPT	1/8 NPT	0.250	3/16	27
21 AS-02NPT	1/4 NPT	0.406	1/4	18
21 AS-03NPT	3/8 NPT	0.406	5/16	18
21 AS-04NPT	1/2 NPT	0.531	3/8	14
21 AS-06NPT	3/4 NPT	0.531	9/16	14
21 AS-08NPT	1 NPT	0.656	4/8	11 1/2

Flexible Uni-Joint Tube

สายยางประหยัดพื้นที่ สำหรับส่งน้ำหล่อเย็น รุนงอตัวได้ใช้พื้นที่แนวตั้งให้เป็นประโยชน์และสามารถโค้งหลบ สิ่งกีดขวางต่างๆที่ยื่นออกมาจากแม่พิมพ์

Cooling pipe that require less piping space, the Flexible pipe can bend to avoid obstacle in vertical space.

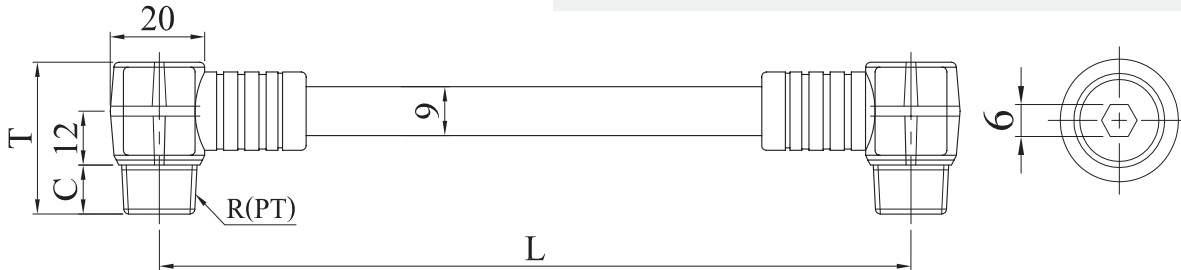

⚠ Max Pressure: 14.7 Bar
Max Temperature: 80°C
For water

Ⓜ Screw Body: Brass
Tube: Urethane

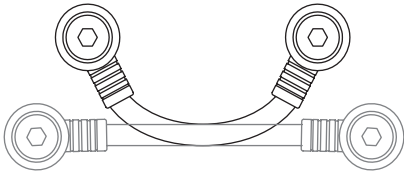

Order Code	R(PT)	L	T	C	Max Torque
21 FC01-140	1/8PT	140	31	9	4.9 N·m
21 FC02-140	1/4PT	140	35	12.7	8.8 N·m